

HIGHWAY LANDSCAPE DEVELOPMENT PROJECT

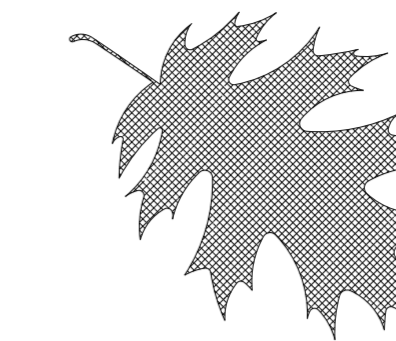

T.I.P. #	STATE PROJECT W.B.S. #	SHEET #	SHEET # TOTAL
-	36059.157	L1.0	7
FED. PROJ. #	DESCRIPTION		DIVISION
-	US 221 Bypass		13

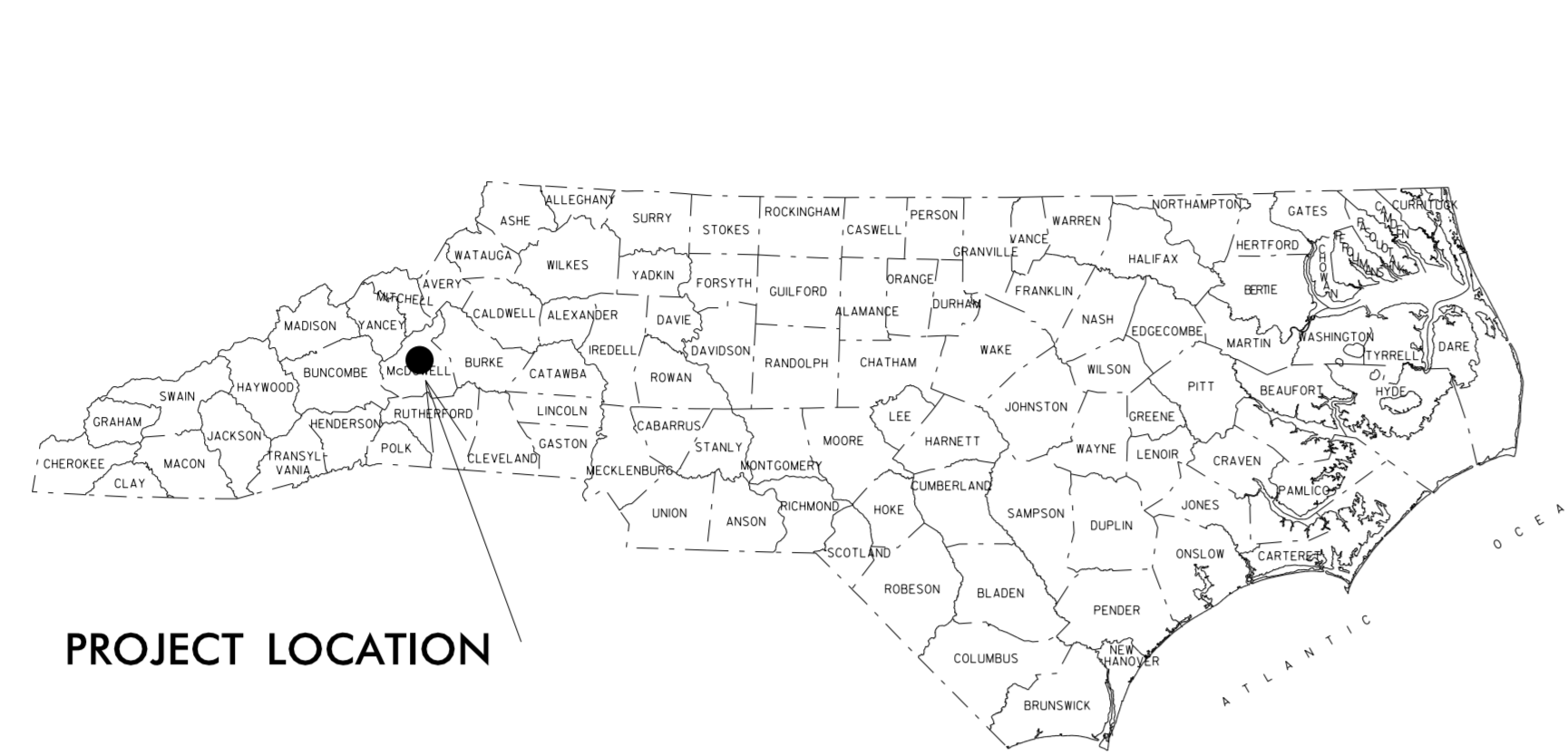

MCDOWELL COUNTY WELCOME CENTER REST AREA

PROJECT: 36059.157

Des	Sec	Qty.	Unit	Key	Botanical Name	Common Name	Size	Caliper	Furnish	A.S.N.S.	Remarks
L	1670	6	EA	ap	<i>Acer palmatum</i> 'Moonfire'	Moonfire Japanese Maple	7'		#10 cont.	1.2.4	As Shown
L	1670	290	EA	hh	<i>Hemerocallis</i> 'Happy Returns'	Happy Returns Daylily			#1 cont.	12.2.3	As Shown
L	1670	57	EA	jp	<i>Juniperus procumbens</i> 'Nana'	Dwarf Japanese Garden Juniper	12-15"		#3 cont.	3.2.2	As Shown
L	1670	358	EA	lm	<i>Liriope muscari</i> 'Variegata'	Variegated Liriope			#1 cont.	12.5	As Shown
L	1670	174	EA	mc	<i>Muhlenbergia capillaris</i>	Pink Muhley Grass	18-24"		#3 cont.	12.4	As Shown
L	1670	37	EA	nd	<i>Nandina domestica</i> 'Harbour Dwarf'	Harbour Dwarf Nandina	18-24"		#3 cont.	4.2.2	As Shown
L	1670	7	EA	pj	<i>Pieris japonica</i> 'Cavatine'	Cavatine Pieris	18-24"		#3 cont.		As Shown
L	1670	82	EA	pa	<i>Pennisetum alopecuroides</i> 'Hamlin'	Dwarf Fountain Grass			#1 cont.	12.4	As Shown
L	1670	4	EA	pg	<i>Picea glauca</i> 'conica'	Serbian Spruce	18-24"		#3 cont.	3.2.5	As Shown
L	1670	83	EA	sj	<i>Sedum x 'Autumn Joy'</i>	Autumn Joy Stonecrop			#1 cont.	6.4.1	As Shown
L	1670	2	EA	to	<i>Thuja occidentalis</i> 'Rheingold'	Reingold Arborvitae	8-12"		#3 cont.	3.2.6	As Shown
2729	1670	69	cy		Mulch for Planting						
2731	1670	3	m/g		Water for Planting						
L	1670	1073	sy		Plant Bed Removal						
2732	1670	1700	sy		Sod Installation (Tall Fescue mix)						
L	1670	824	sy		Pre emergence Herbicidal Treatment						
L	1670	824	sy		Post emergence Herbicidal Treatment						
SP	1670	2026	lf		Commercial Grade Steel Landscape Metal Edging, 4" wide, 12 ga., Brown powder coat finish						

CONVENTIONAL SYMBOLS

County Line.....	-----
City or Town Line.....	-----
Exist. Right of Way Line Marker.....	-----
Prop. Right of Way Line Marker (By Others).....	-----
Prop Right of Way Line Marker (By Contract).....	-----
Exist. Control of Access Line.....	-----
Prop. Control of Access Line.....	-----
Property Line.....	-----
Easement Line.....	-----
Slope Stake Line.....	-----
Exist. Fence.....	-----
Prop. Woven Wire Fence.....	-----
Prop. Chain Link Fence.....	-----
Exist. Road.....	-----
Prop. Road.....	-----
Guardrail.....	-----
Survey Line.....	-----
Denotes Line Equality.....	-----
Bridge.....	-----
Culvert.....	-----
Railroad.....	-----
Woods.....	-----
Exist. Telephone Pole.....	-----
Prop. Telephone Pole.....	-----
Tower Pole and Line.....	-----
Exist. Power Pole.....	-----
Prop. Power Pole.....	-----
Sanitary Sewer Line.....	-----
Water Line.....	-----
Gas Line.....	-----
Picnic Shelter.....	-----
Regeneration.....	-----
Reforestation.....	-----

INDEX OF L SHEETS:

- L 1.0 ... TITLE, DESCRIPTION, LOCATION
- L 2.0 ... PLANTING DETAILS
- L 3.0 ... DEMOLITION PLAN
- L 4.0 ... SOD PLAN
- L 5.0 ... MASTER PLAN
- L 6.0 L 7.0 ... PLANTING PLANS

PREPARED BY: BM DATE: 3/2013

REVISIONS

DATE	DESCRIPTION

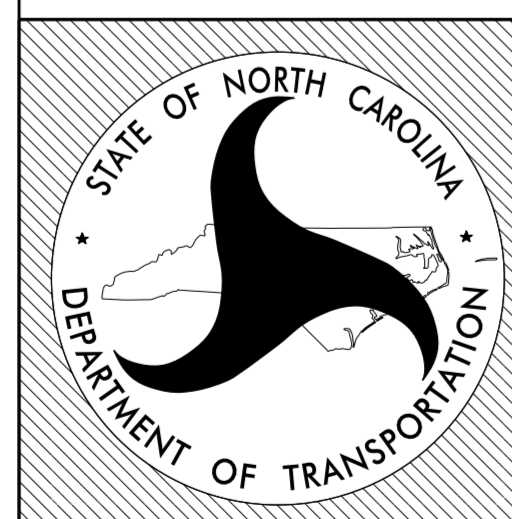

STATE OF NORTH CAROLINA DEPARTMENT OF TRANSPORTATION

LOCATION: US 221 BYPASS WELCOME CENTER / REST AREA

TYPE of WORK: LANDSCAPE PLANTING RENOVATION

COUNTY: MCDOWELL COUNTY

2004 American Standard for Nursery Stock
2012 NCDOT STANDARD SPECIFICATIONS
PREPARED IN THE OFFICE OF:
NCDOT- ROADSIDE ENVIRONMENTAL UNIT
LANDSCAPE DESIGN & DEVELOPMENT SECTION
1557 MAIL SERVICE CENTER
RALEIGH NC 27699 919-707-2920

\$\$\$\$\$SYTIME\$\$\$\$\$
\$\$\$\$\$SUBNAME\$\$\$\$\$

Snap fence to RED points for 11x17"

Edit Text in WHITE for Your Project

Snap Fence to YELLOW points for 22 x 34":

Rotate 270 degrees.

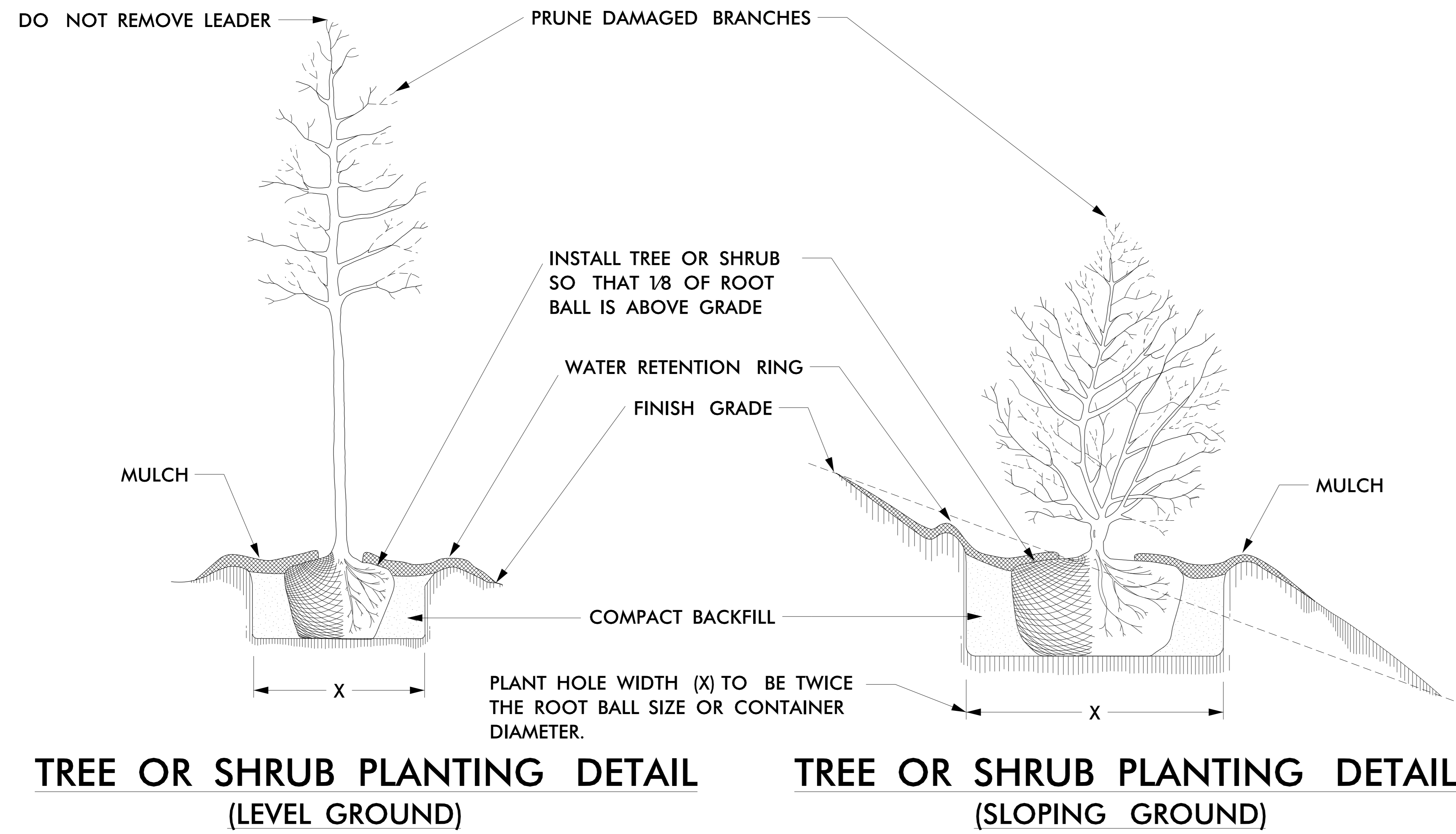

TREE OR SHRUB PLANTING DETAIL
(LEVEL GROUND)

TREE OR SHRUB PLANTING DETAIL
(SLOPING GROUND)

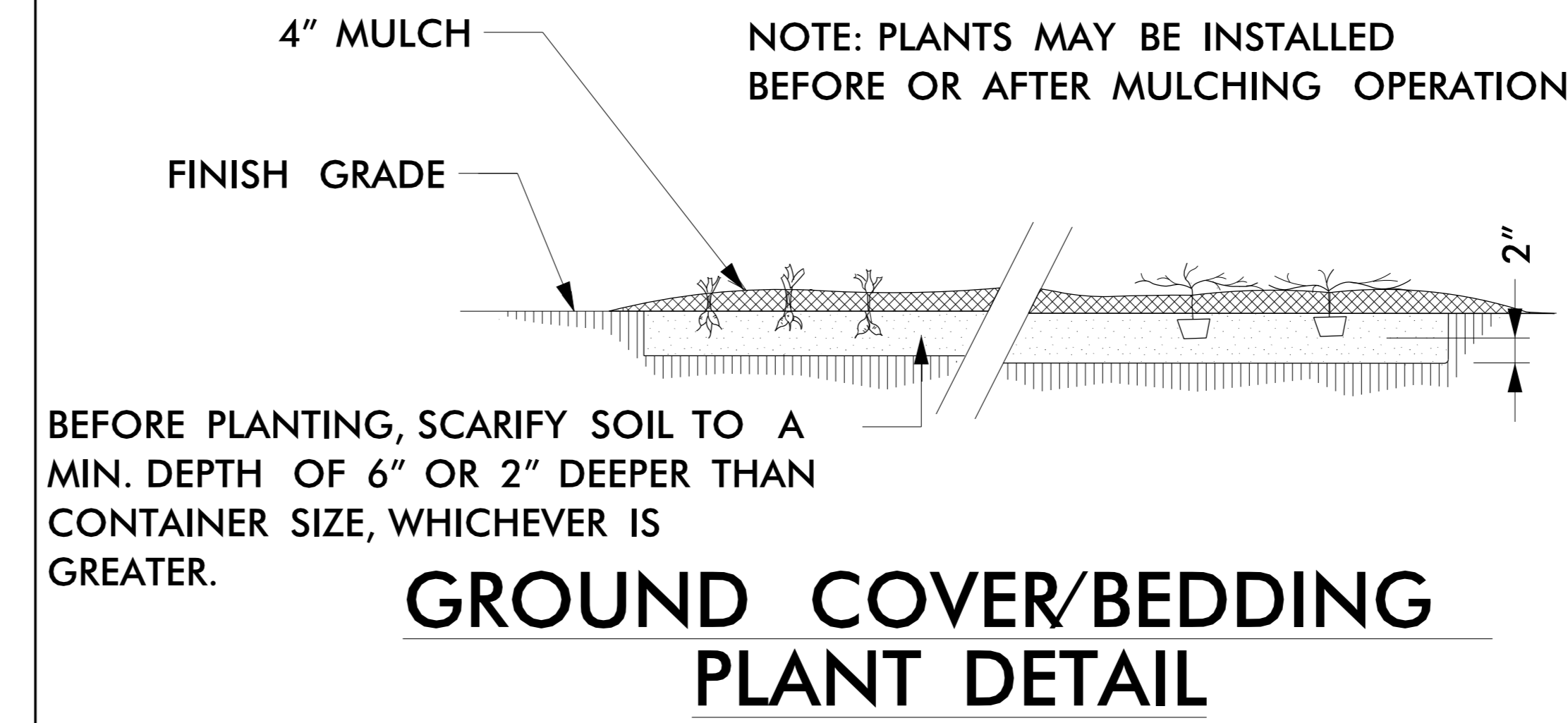

GROUND COVER/BEDDING PLANT DETAIL

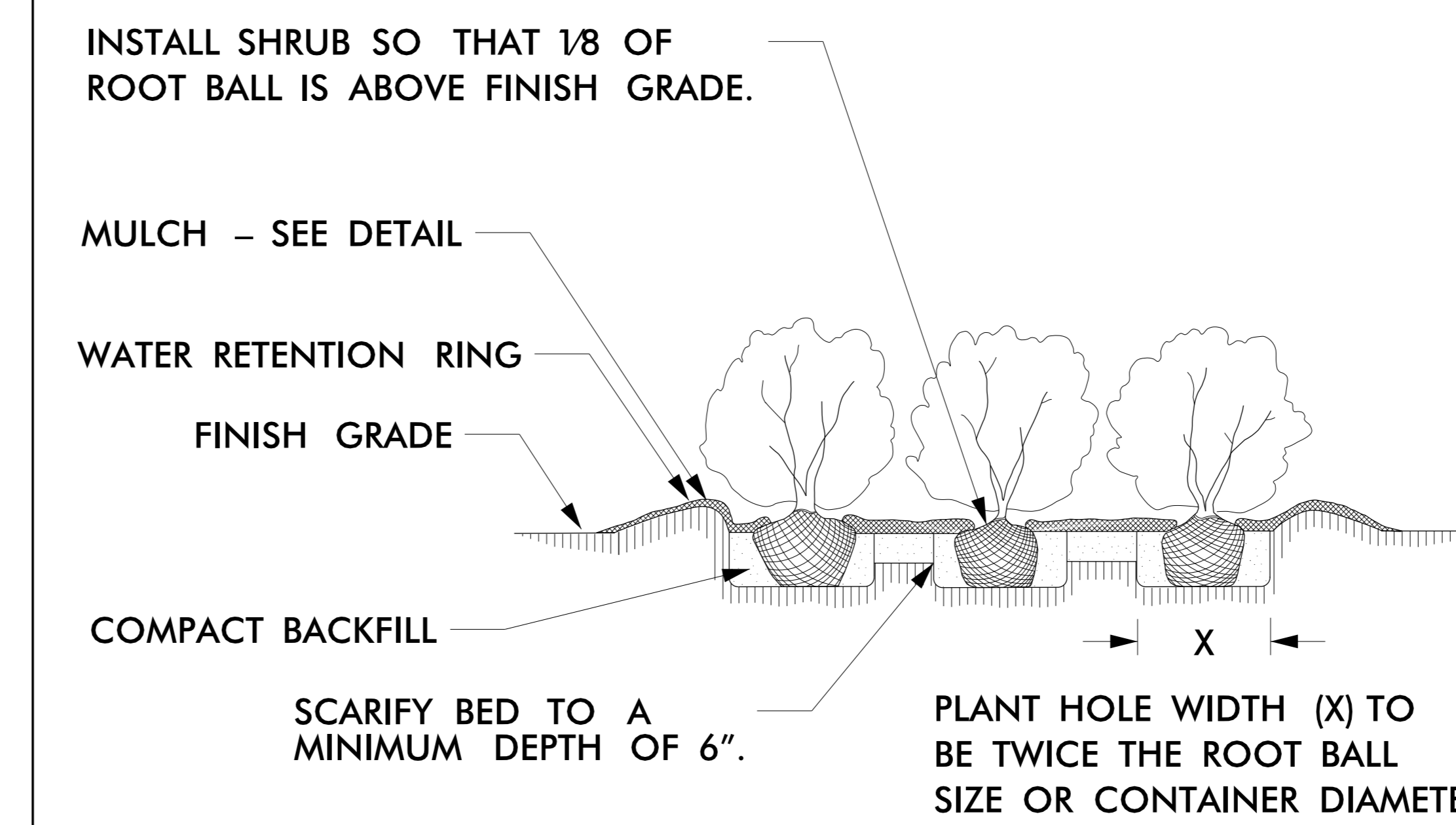

SHRUB BED PLANTING DETAIL

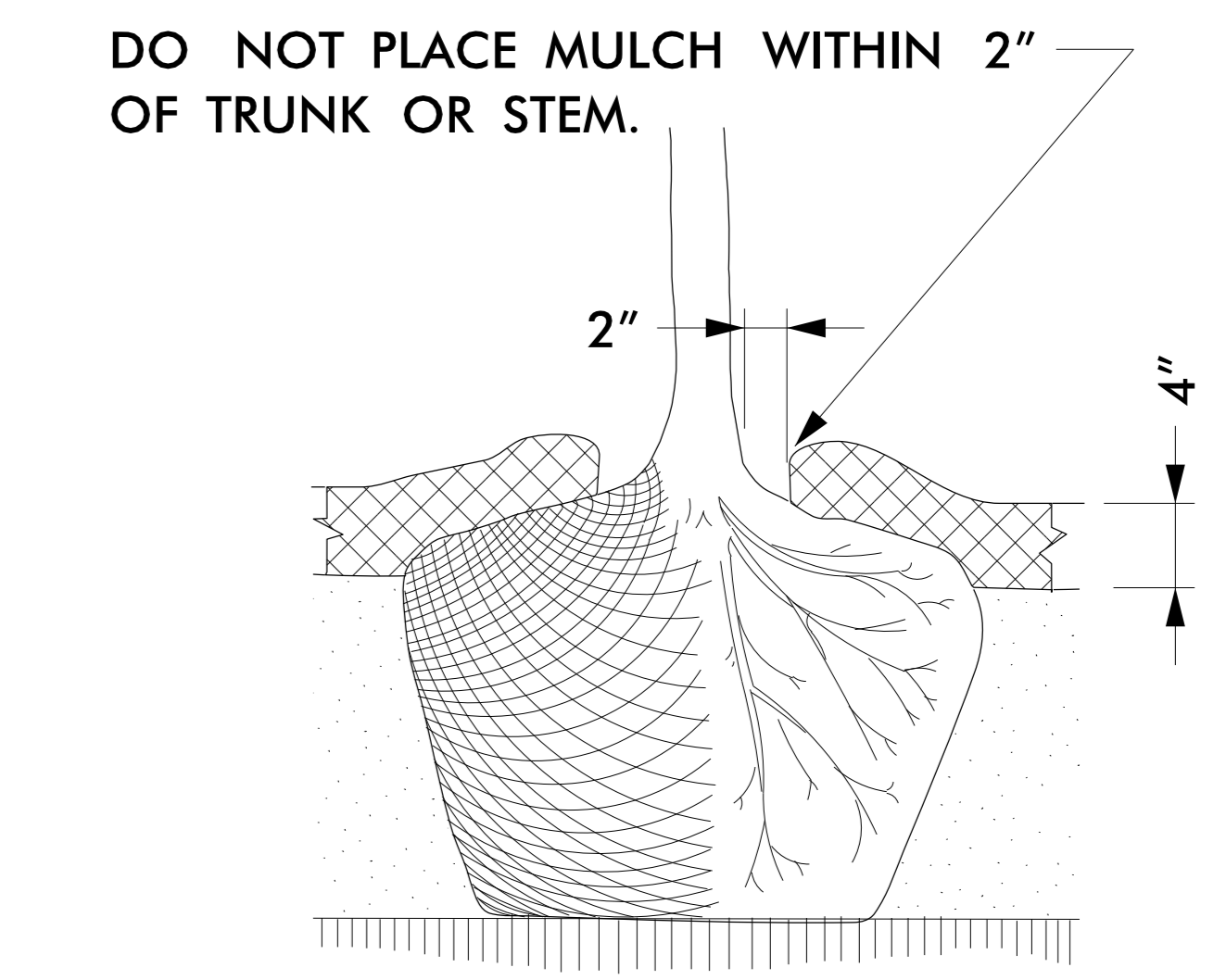

MULCH DETAIL

- NOTES:**
- SCHEDULE FOR PLANT HOLE SIZE: PLANT HOLE WIDTH (X) TO BE TWICE THE ROOT BALL SIZE OR CONTAINER DIAMETER.
 - SEE STANDARD SPECIFICATIONS FOR PLANT BED FUMIGATION AND HERBICIDAL TREATMENT.
 - APPLY FERTILIZER AT PLANTING TIME IN THE FORM OF A SLOW RELEASE PELLET OR TABLET. APPLY AT RATE RECOMMENDED BY MANUFACTURER. BOTH RATE AND FORMULATION MUST BE APPROVED BY FIELD ENGINEER PRIOR TO APPLICATION.
 - REMOVE WIRE BASKET AND FOLD BURLAP BACK FROM TOP OF ROOT BALL BEFORE BACKFILLING IS COMPLETE.
 - ALL PRUNING TO FOLLOW STANDARD ARBORICULTURAL PRACTICES AS SPECIFIED BY INTERNATIONAL SOCIETY OF ARBORICULTURE.
 - DO NOT ATTEMPT TO STRAIGHTEN A TREE THAT HAS BEEN PLANTED AT AN ANGLE WITH THE USE OF STAKING OR GUYING. DIG TREE AND REPLANT TO UPRIGHT POSITION.

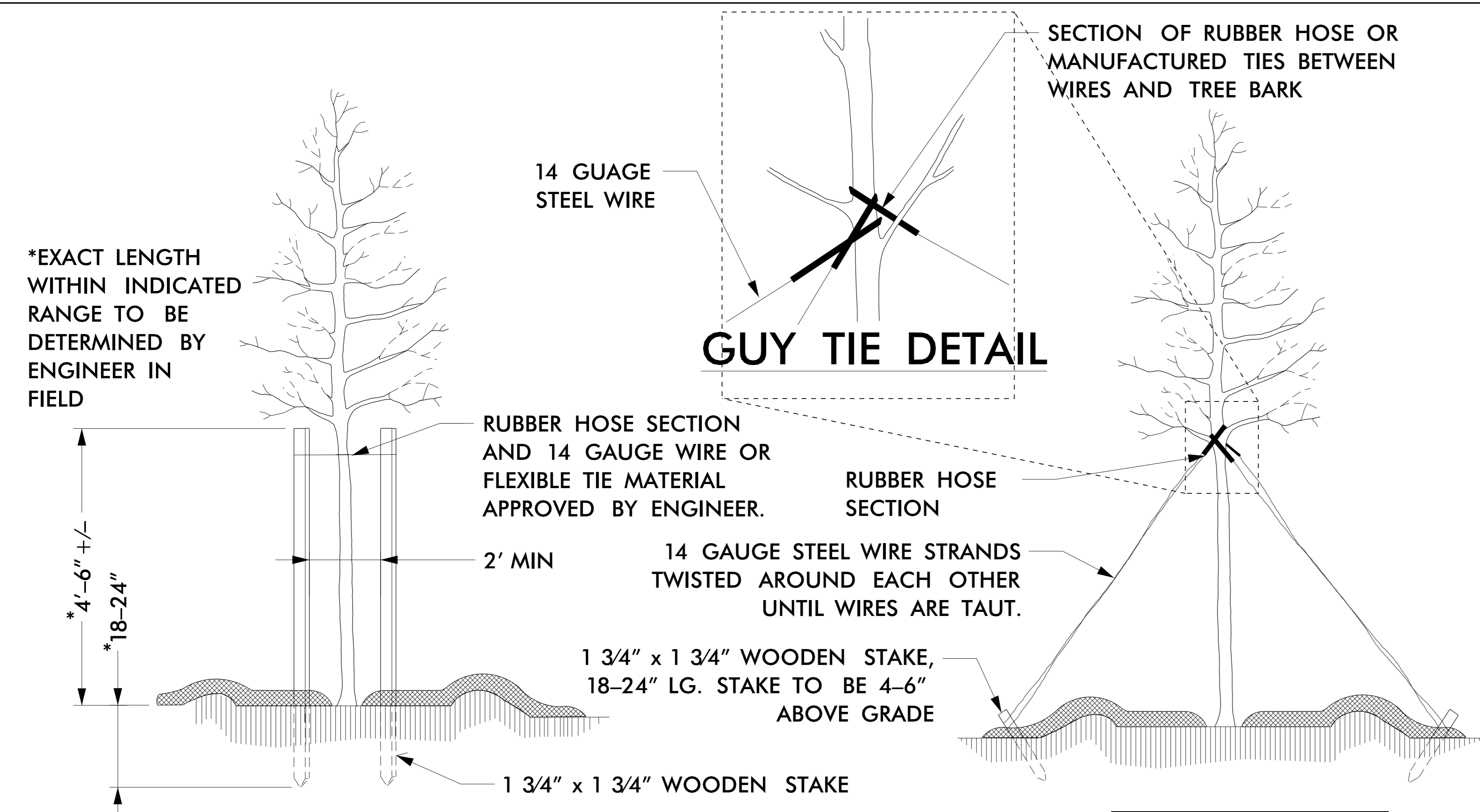

GUY TIE DETAIL

PLAN VIEW STAKING DETAIL
(TREES 6'-10')

USE AS DIRECTED BY FIELD ENGINEER

PLAN VIEW GUYING DETAIL
(TREES 10' OR LARGER)

USE AS DIRECTED BY FIELD ENGINEER

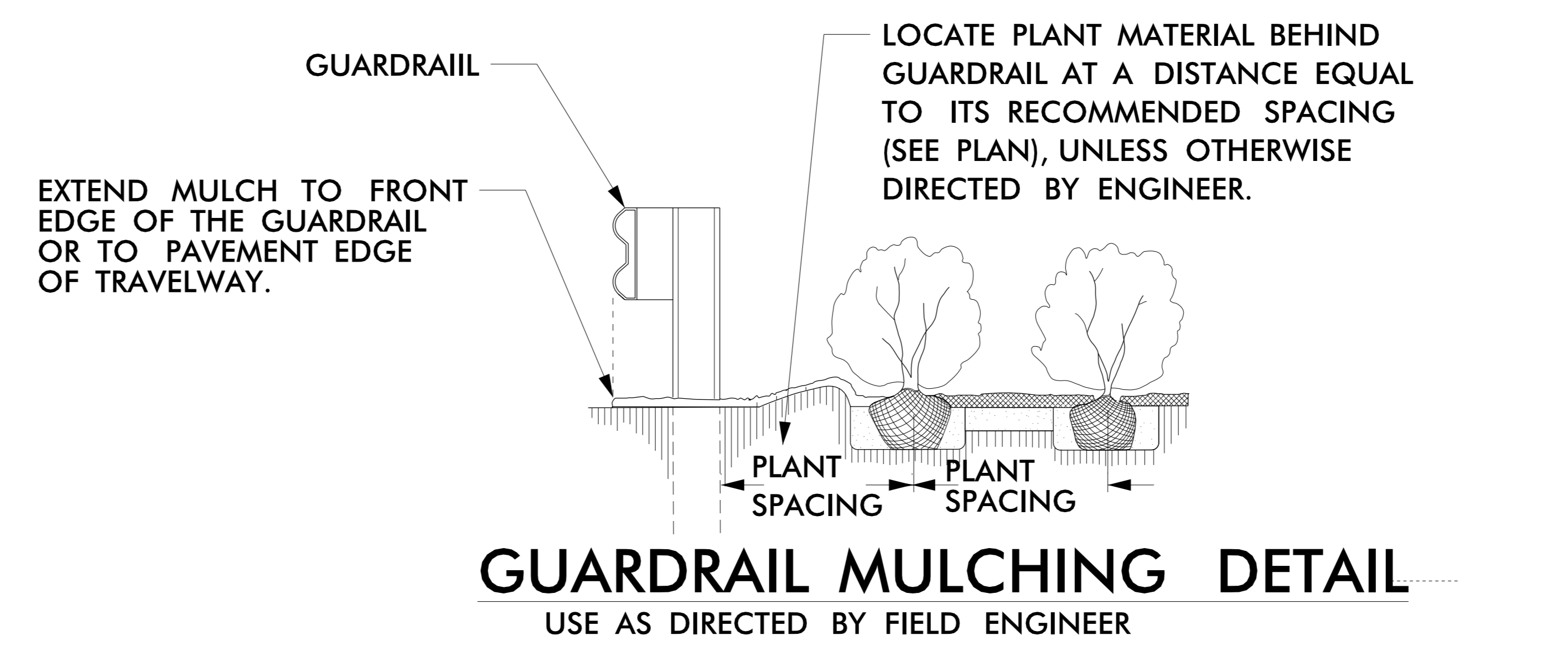

GUARDRAIL MULCHING DETAIL

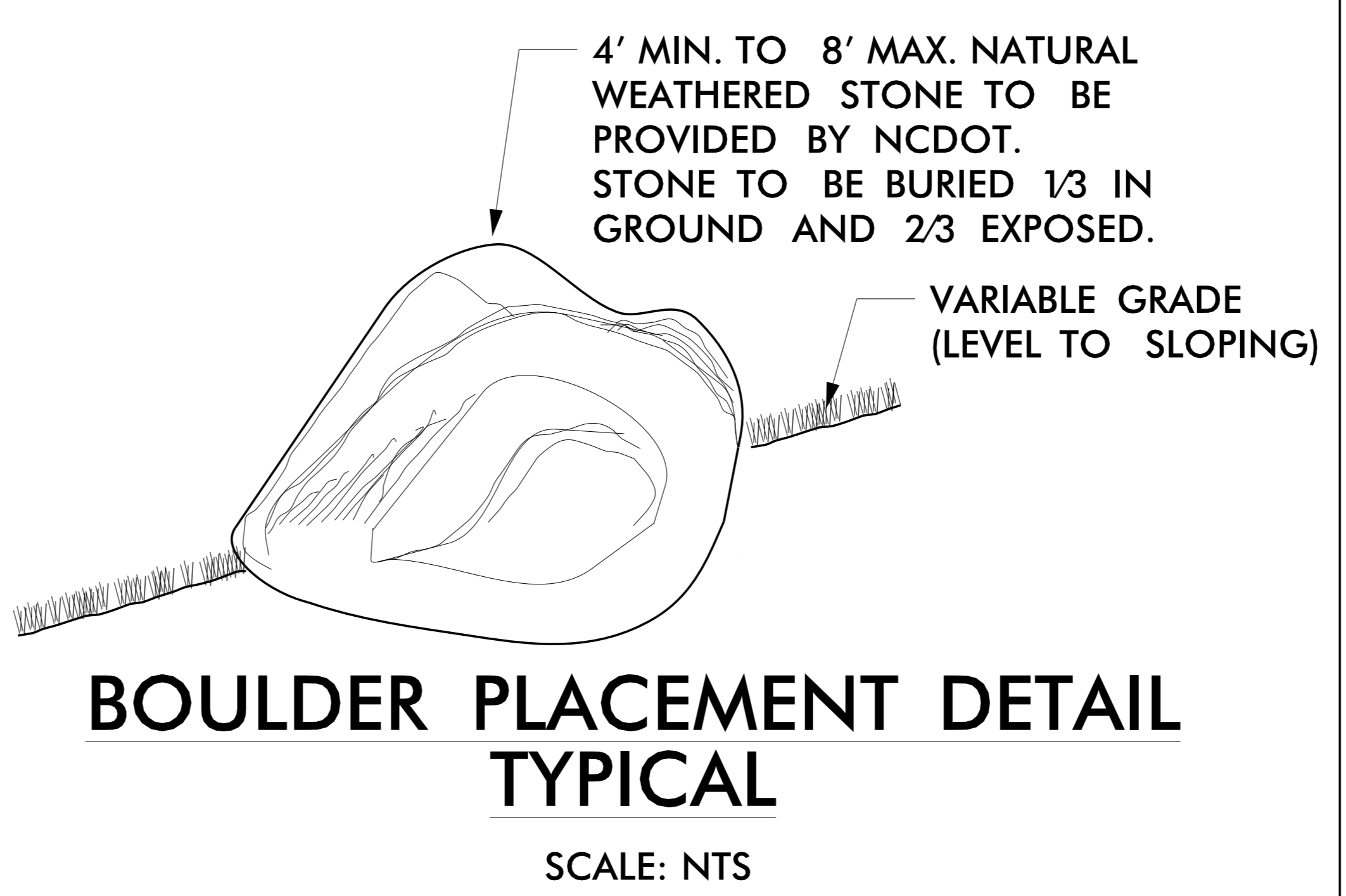

BOULDER PLACEMENT DETAIL TYPICAL

SCALE: NTS

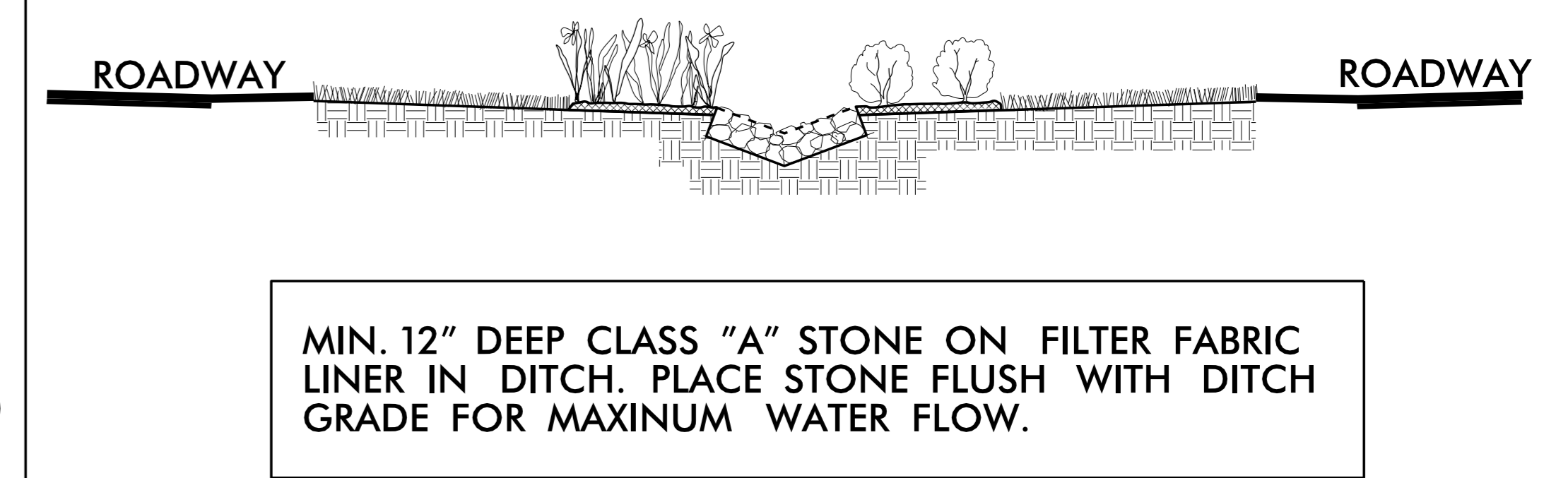

CLASS "A" STONE DITCH LINING DETAIL

Planting Details

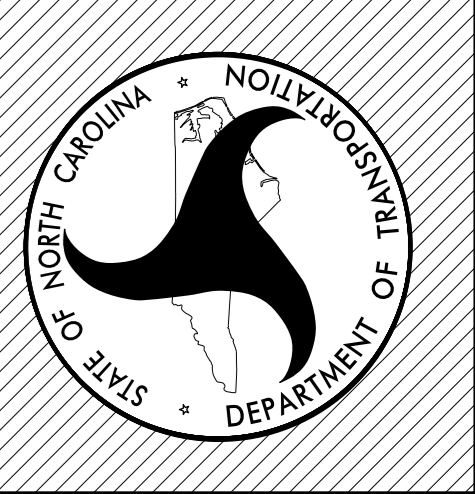

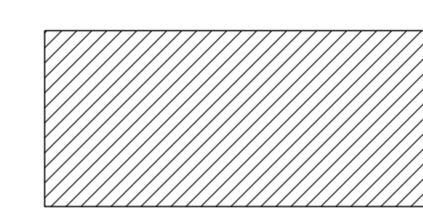
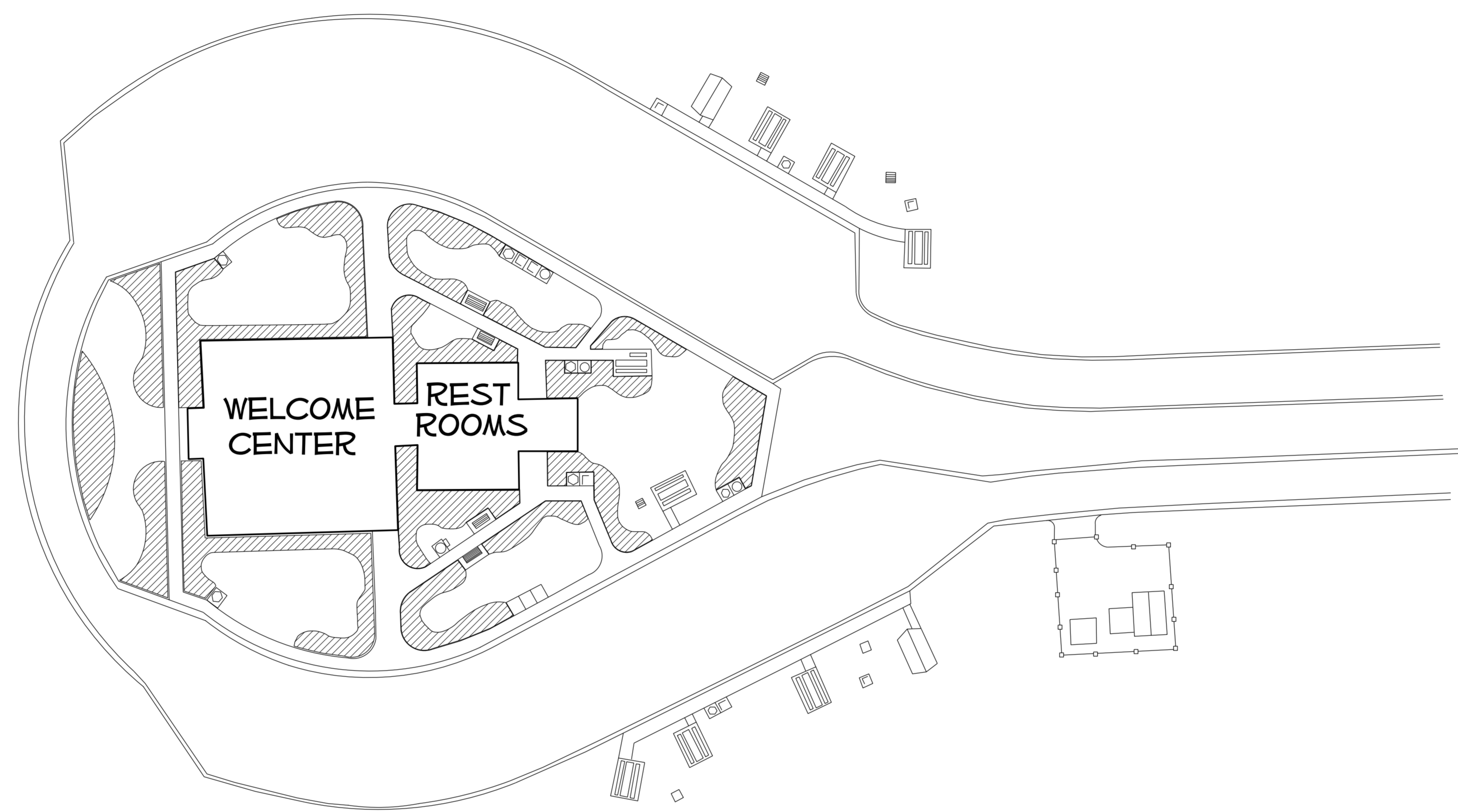

*DENOTES: REMOVE ALL PLANTS AND ROOTS. DO NOT DAMAGE UNDER GROUND UTILITIES DURING PLANT REMOVAL. FOLLOW DIRECTION OF DIVISION ROADSIDE ENGINEER.

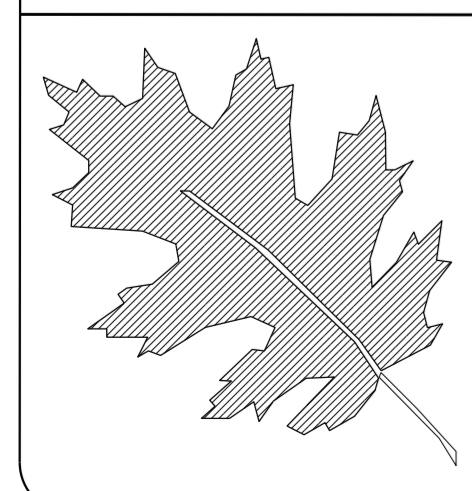

NCDOT - ROADSIDE ENVIRONMENTAL UNIT
 LANDSCAPE DESIGN & DEVELOPMENT
 1557 MAIL SERVICE CENTER, RALEIGH, NC 27699-1557
 PH: 919-707-2935 FAX: 919-715-2554
[HTTP://WWW.NCDOT.ORG/DOH/OPERATIONS/DP_CHIEF_ENG/ROADSIDE/](http://www.ncdot.org/DOH/OPERATIONS/DP_CHIEF_ENG/ROADSIDE/)

MCDOWELL COUNTY REST AREA
 US 221 BYPASS
 PROJECT #: 36059.157

REV ENGINEER :
B. Minter Sr.

SHEET DESCRIPTION:	LANDSCAPE RENOVATION
	DEMOLITION PLAN

PREL DESIGN DATE:	FALL 2012
CHECKED BY & DATE:	N. RING
FINAL DESIGN DATE:	SPRING 2013

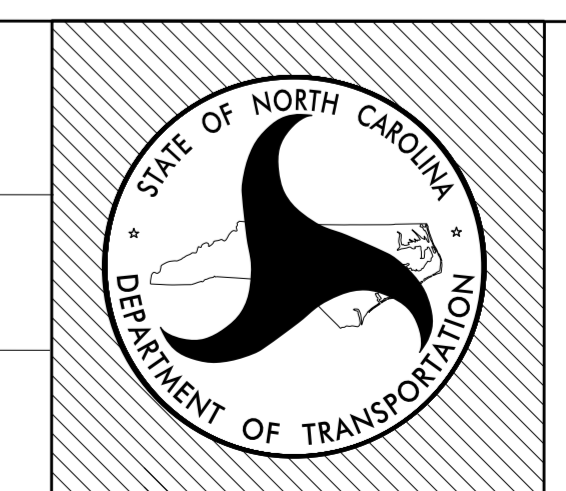

SHEET NO :
L-3
 TOTAL SHEET NO : 7

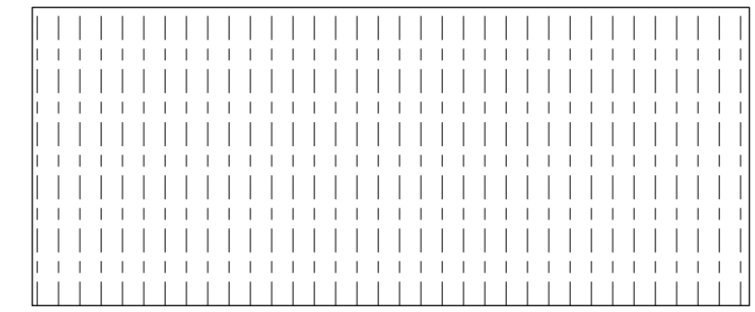

*DENOTES: REMOVE EXISTING LAWN TURF. PROPOSED SOD AREAS MUST BE TILLED AND RAKED LEVEL. SOD PLACEMENT IS TO BE ACROSS FACE OF SLOPE. INSTALL SOD STAPLES TO PREVENT MOVEMENT ON STEEP SLOPE AREAS. FOLLOW DIRECTION OF DIVISION ROADSIDE ENGINEER.

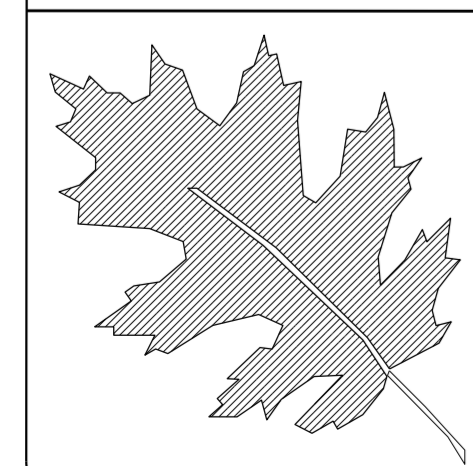
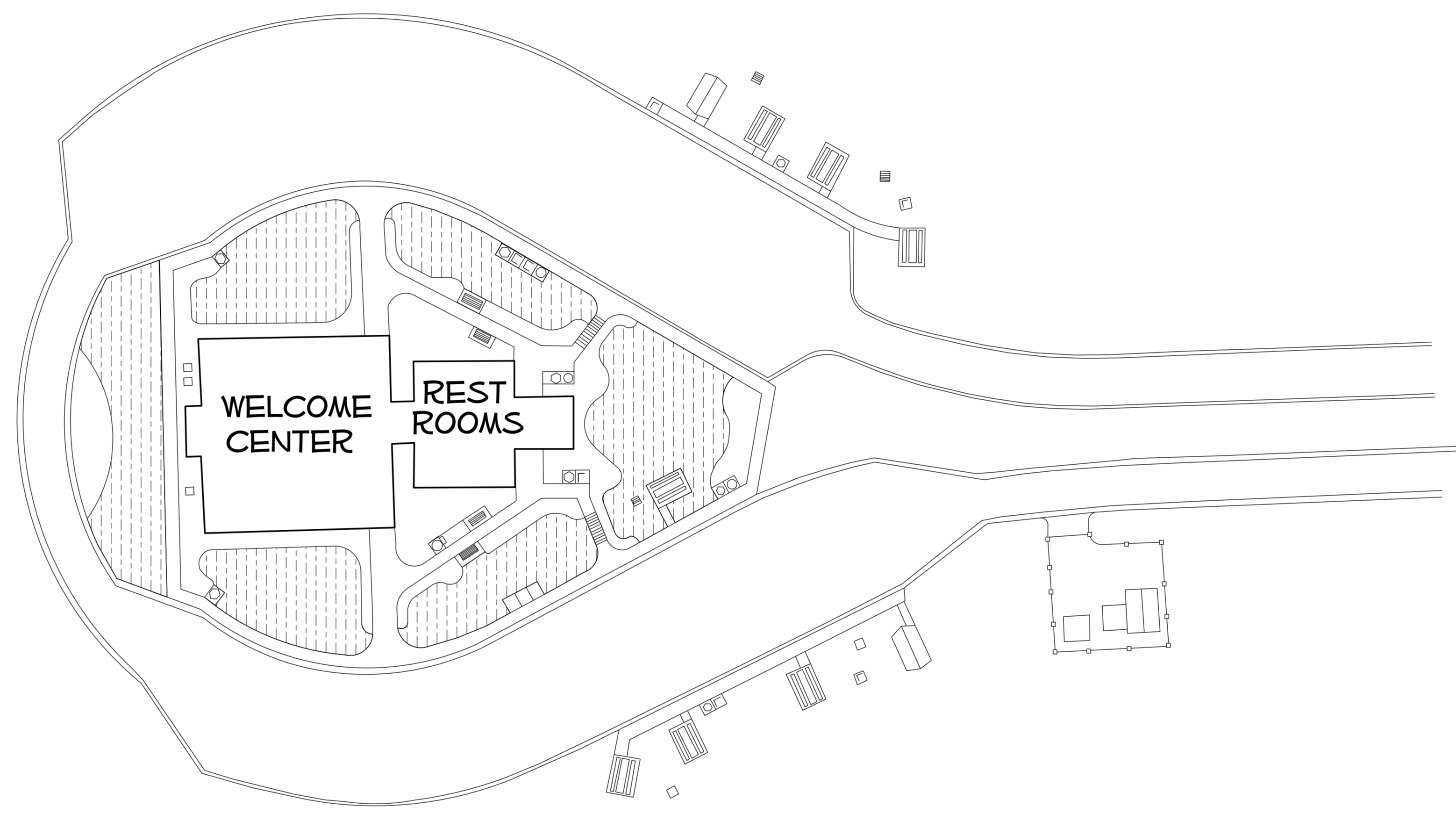

NCDOT - ROADSIDE ENVIRONMENTAL UNIT
 LANDSCAPE DESIGN & DEVELOPMENT
 1557 MAIL SERVICE CENTER, RALEIGH, NC 27699-1557
 PH: 919-707-2935 FAX: 919-715-2554
[HTTP://WWW.NCDOT.ORG/DOH/OPERATIONS/DP_CHIEF_ENG/ROADSIDE/](http://www.ncdot.org/DOH/OPERATIONS/DP_CHIEF_ENG/ROADSIDE/)

McDOWELL COUNTY REST AREA
 US 221 BYPASS
 PROJECT #: 36059.157

REU ENGINEER:
B. Minter Sr.

SHEET DESCRIPTION:	LANDSCAPE RENOVATION
	SOD PLAN SHEET

PREL DESIGN DATE:	FALL 2012
CHECKED BY & DATE:	N. RING
FINAL DESIGN DATE:	SPRING 2013

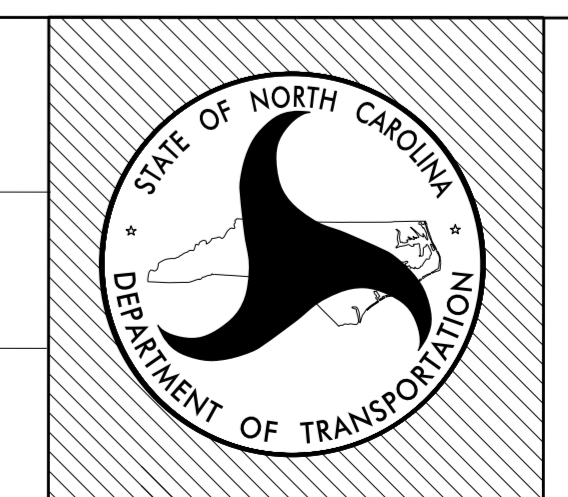

SHEET NO :
L-4
 TOTAL SHEET NO :
 7

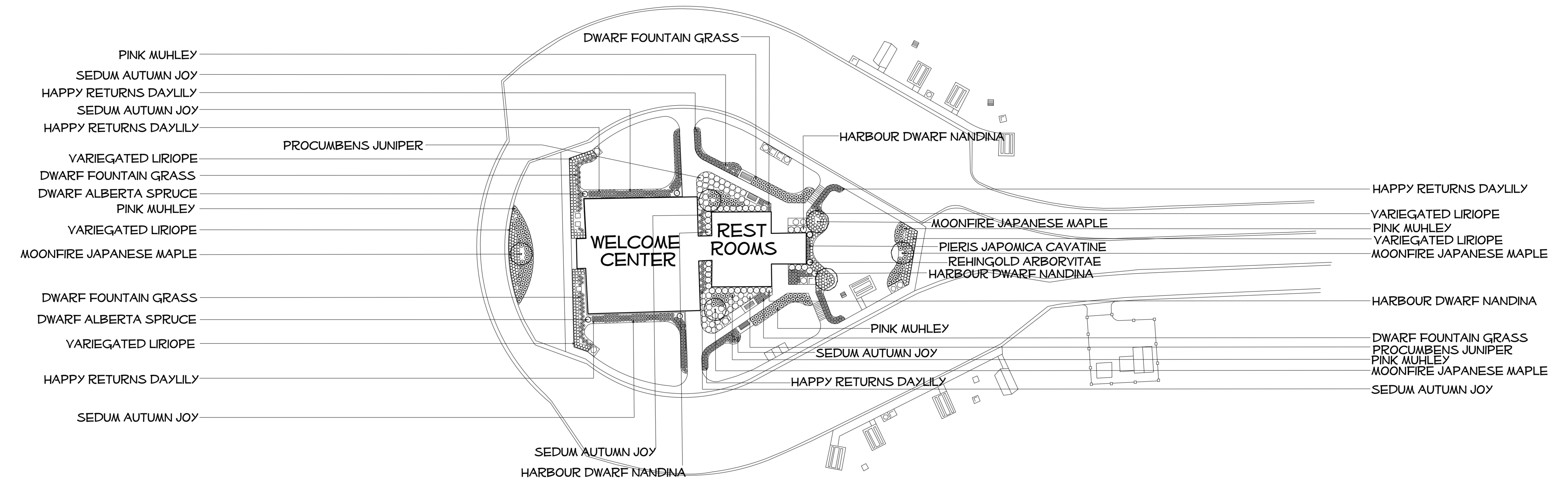

*NOTE: SEE PLAN SHEETS 6 & 7 FOR LARGER PLAN VIEW AND PLANT QUANTITIES

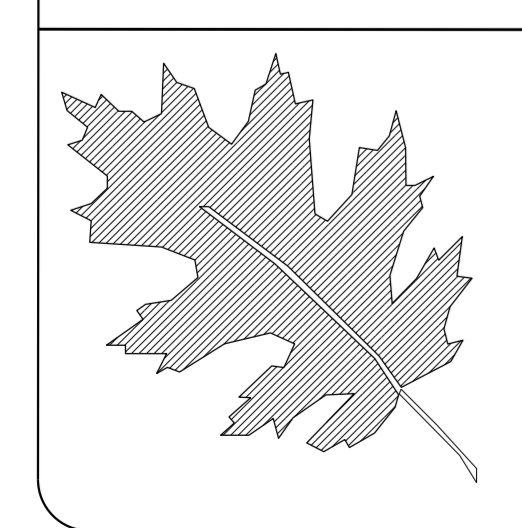

NCDOT - ROADSIDE ENVIRONMENTAL UNIT
 LANDSCAPE DESIGN & DEVELOPMENT
 1557 MAIL SERVICE CENTER, RALEIGH, NC 27699-1557
 PH: 919-707-2935 FAX: 919-715-2554
 HTTP://WWW.NCDOT.ORG/DOH/OPERATIONS/DP.CHIEF.ENG/ROADSIDE/

MCDOWELL COUNTY REST AREA
 US 221 BYPASS
 PROJECT #: 36059.157

REU ENGINEER:
B. Minter Sr.

SHEET DESCRIPTION:
 LANDSCAPE RENOVATION
 LANDSCAPE MASTER PLAN

PREL DESIGN DATE: FALL 2012
 CHECKED BY & DATE: N. RING
 FINAL DESIGN DATE: SPRING 2013

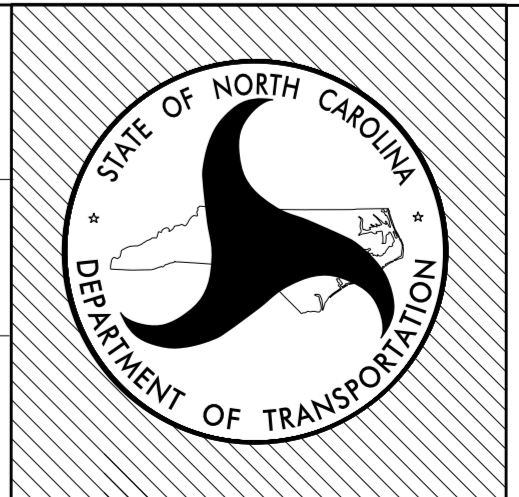

SHEET NO: **L-5**
 TOTAL SHEET NO: 7

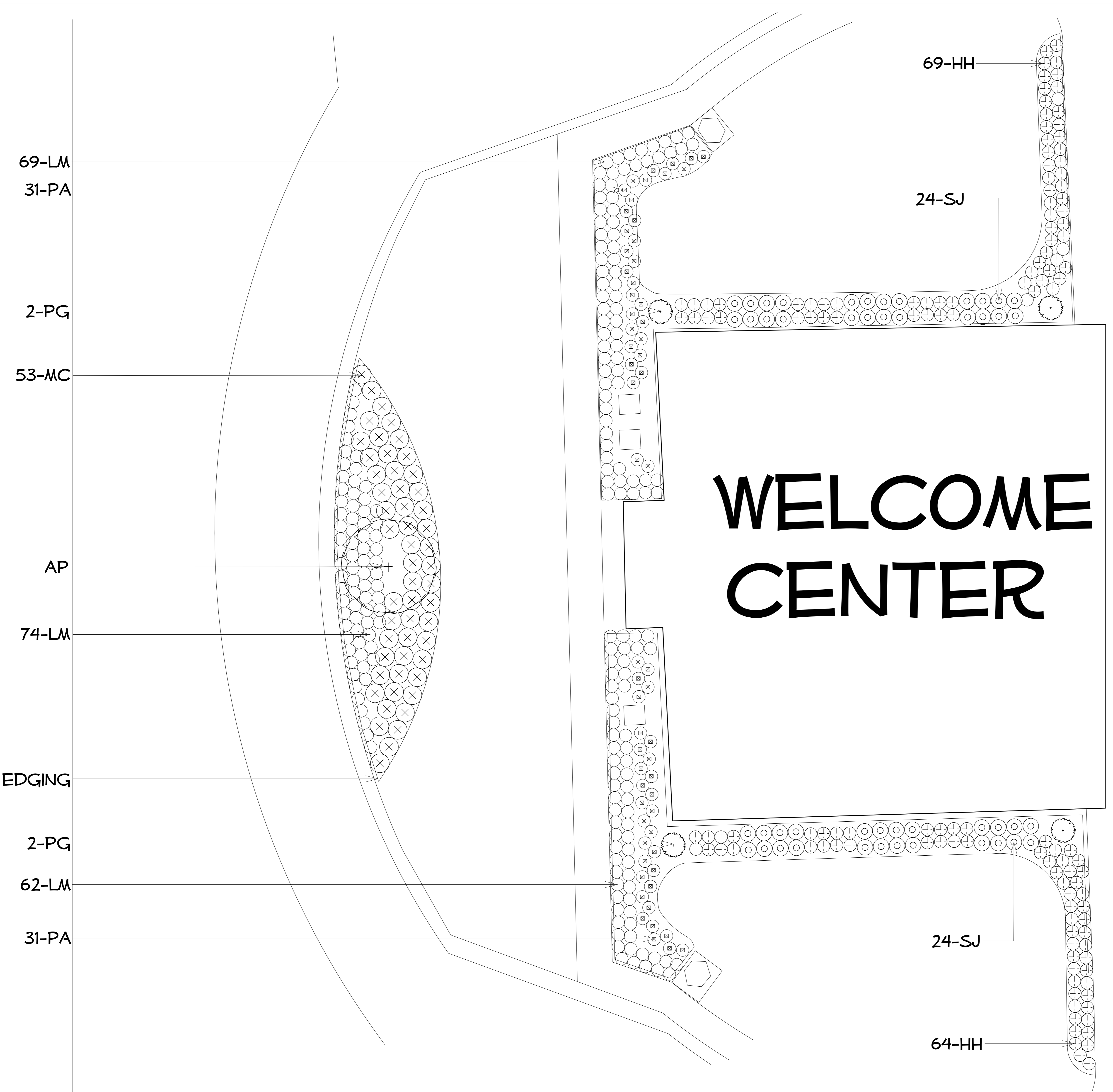

PLANT LIST

QUAN	UNIT	KEY	BOTANICAL NAME	COMMON NAME	REMARKS
1	EA	ap	Acer palmatum 'Moonfire'	Moonfire Japanese Maple	AS SHOWN
133	EA	HH	HEMEROCALLIS 'HAPPY RETURNS'	HAPPY RETURNS DAYLILY	AS SHOWN
	EA	JP	JUNIPERUS PROCUMBENS 'NANA'	DWARF JAPANESE GARDEN JUNIPER	AS SHOWN
205	EA	LM	LIRIOPE MUSCARI 'VARIEGATA'	VARIEGATED LIRIOPE	AS SHOWN
53	EA	MC	MUHLENBERGIA CAPILLARIS	PINK MUHLEY GRASS	AS SHOWN
	EA	ND	NANDINA DOMESTICA 'HARBOUR DWARF'	HARBOUR DWARF NANDINA	AS SHOWN
	EA	PJ	PIERIS JAPONICA 'CAVATINE'	CAVATINE PIERIS	AS SHOWN
62	EA	PA	PENNISETUM ALOPECUROIDES 'HAWELN'	DWARF FOUNTAIN GRASS	AS SHOWN
4	EA	PG	PICEA GALAUCA 'CONICA'	DWARF ALBERTA SPRUCE	AS SHOWN
48	EA	SJ	SEDUM X 'AUTUMN JOY'	AUTUMN JOY STONE CROP	AS SHOWN
	EA	TO	THUJA OCCIDENTALIS 'RHEINGOLD'	RHEINGOLD ARBORVITAE	AS SHOWN

*NOTE : FIELD ADJUSTMENTS ARE TO BE APPROVED BY DIVISION ROADSIDE ENGINEER



\$\$\$\$\$SYTIME\$\$\$\$\$
\$\$\$\$\$USERNAM\$\$\$\$\$

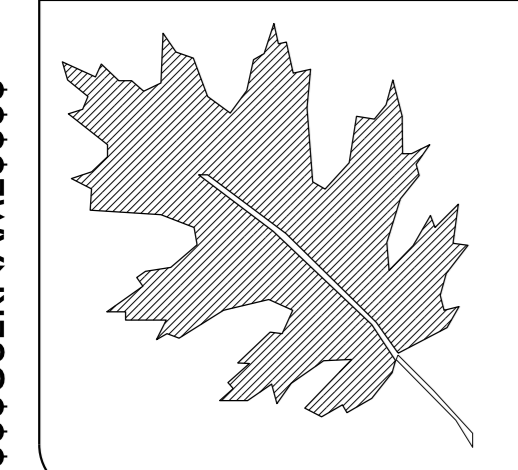

NCDOT - ROADSIDE ENVIRONMENTAL UNIT
LANDSCAPE DESIGN & DEVELOPMENT
1557 MAIL SERVICE CENTER RALEIGH NC 27699-1557
PH: 919-707-2935 FAX: 919-715-2554
HTTP://WWW.NCDOT.ORG/DOH/OPERATIONS/DP.CHEF.ENG/ROADSIDE/

MCDOWELL COUNTY REST AREA
US 221 BYPASS
CONTRACT #: 36059.157
REU ENGINEER:
B. Winter Sr.

SHEET DESCRIPTION:
PREL DESIGN DATE: FALL 2012
CHECKED BY & DATE: N. RING
FINAL DESIGN DATE: SPRING 2013

LANDSCAPE RENOVATION
LANDSCAPE PLAN SHEET

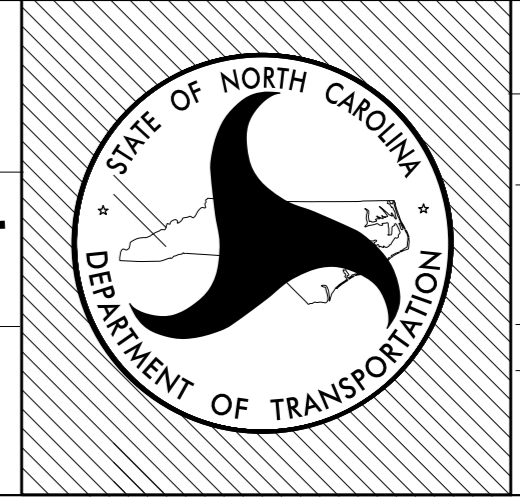

T.I.P. #
WBS # 36059.157
FED I.D. #
SHEET NO: L-6 TOTAL SHEET NO: 7

